

Physical Constants:

- proton charge = $e = 1.60 \times 10^{-19} \text{ C}$
- permittivity = $\epsilon_0 = 8.85 \times 10^{-12} \text{ C}^2/(\text{N} \cdot \text{m}^2)$
- Coulomb constant = $k = 9 \times 10^9 \text{ N} \cdot \text{m}^2/\text{C}^2$

Select the letter of the single best answer. Each answer is worth 1 point.

1. How many of the following unit equations are correct?

- $V = \text{J}/\text{C}$
- $A = \text{C}/\text{s}$
- $\Omega = \text{V}/\text{A}$
- $F = \text{C}/\text{V}$
- $W = \text{N}/\text{s}$ NO

- A. two
- B. three
- C. four
- D. none of the above

2. A $6 \mu\text{F}$ and a $3 \mu\text{F}$ capacitor are connected in series and charged with a 9 V battery.

- $v = \frac{q}{C}$ A. The voltage drop across the $6 \mu\text{F}$ capacitor is half the voltage drop across the $3 \mu\text{F}$ capacitor.
- B. The charge stored on the $6 \mu\text{F}$ capacitor is equal to the charge stored on the $3 \mu\text{F}$ capacitor.
- $\frac{6 \cdot 3}{4} = 2$ C. Together the two capacitors act like one $2 \mu\text{F}$ capacitor.
- D. All of the above are true.

3. 9 V is placed across the terminals of a $3 \mu\text{F}$ capacitor, approximately how much energy is stored in the capacitor?

- A. $3 \mu\text{J}$
- B. $27 \mu\text{J}$
- C. $41 \mu\text{J}$
- D. $122 \mu\text{J}$ ←

$\frac{1}{2} (3 \times 10^{-6}) 9^2$

4. 9 V is placed across the terminals of a 3Ω resistor, approximately how much energy is stored in the resistor?

- A. None of the below answers ←
 - B. 27 J
 - C. 41 J
 - D. 122 J
- no power stored

5. A capacitor, with parallel plates separated by a tiny distance d , is connected to a battery which provides a constant emf V . If d is increased slightly how many of the following statements are true?

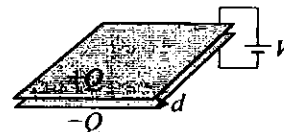

- the capacitance of the capacitor increases NO C ↓
- the charge on the plates decreases ✓
- the energy stored by the capacitor decreases ✓
- the electric field in the middle of the capacitor decreases ✓

- A. four
- B. three ←
- C. two
- D. one

6. A long, buried copper cable connects SJU to the power grid. If at night the current carried in this cable drops to half its daytime value, how many of the following statements about the cable are correct:

- resistance halves $\nu_0 \}$ same
- resistivity halves $\nu_0 \}$ same
- drift velocity halves
- power dissipated in the cable halves

- A. one
 B. two
 C. three
 D. none of the above

7. A solid bar of copper is machined into the shape shown with: $r_B < r_A < r_C$.

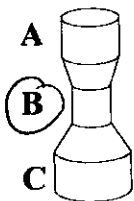

A steady current flows from top to bottom. Circle the location where the electric field, E , is a maximum.

- D. The electric field is the same top-to-bottom so there is no maximum.

$J = \frac{1}{\rho} E$
 $J = \frac{H}{A}$

8. A solid bar of copper is machined into the shape shown with: $r_B < r_A < r_C$.

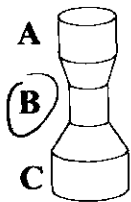

A steady current flows from top to bottom. Circle the location where the current density, J , is a maximum.

- D. The current density is the same top-to-bottom so there is no maximum.

9. A 500 W heater carries a current of 4 A. How much does it cost to operate the heater for 30 minutes if electrical energy costs 6¢ per kW·hr

- A. 1.5 ¢
 B. 6 ¢
 C. 12 ¢
 D. 24 ¢

$\frac{1}{2} \text{ kW} \cdot \frac{1}{2} \text{ hour} \cdot 6 \text{ ¢}$

10. The same components are used to make a series circuit of 10 Ω and 20 Ω resistors and a parallel circuit. In each circuit, which resistor draws the most electrical power?

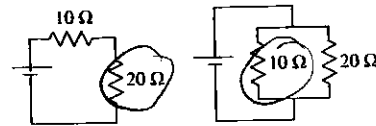

- A. The 10 Ω draws the most power in both circuits.
 B. The 20 Ω draws the most power in both circuits.
 C. The 10 Ω draws the most power in the parallel circuit; the 20 Ω draws the most power in the series circuit.
 D. The 20 Ω draws the most power in the parallel circuit; the 10 Ω draws the most power in the series circuit.

← not used

The following problems are worth 10 points each

11. Calculate the charge on each capacitor in this circuit.

$$12 + \underbrace{(2 \parallel (6+3))}_{\frac{2}{4}} + 1 \Rightarrow \frac{1}{2} + \frac{1}{4} + \frac{1}{1} = \frac{4}{3} \Rightarrow C = \frac{3}{4} \mu F$$

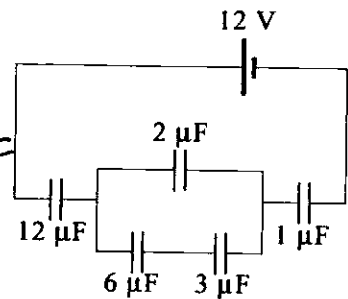

$$Q = (.75 \times 10^{-6}) 12 = 9 \mu C \quad (\text{in } 12 \text{ \& } 1)$$

$$\text{Voltage drops: } \frac{Q}{12} = .75 V \quad \frac{Q}{1} = 9 V \Rightarrow 2.25 V \text{ across } 2 \mu F \text{ \& } 6 \text{ \& } 3$$

$$Q_2 = (2 \mu F)(2.25) = 4.5 \mu C \text{ in } 2$$

$$6+3 \Rightarrow 2 \mu F = 4.5 \mu C \text{ in } 6 \text{ \& } 3$$

note: the $9 \mu C$ in $2 \parallel (6+3)$ must split evenly
 $C \propto \frac{1}{V} \Rightarrow 6+3=2$; That same charge is on
 both the 6 & the 3.

$$\text{result: } 12 \mu F \text{ \& } 1 \mu F \quad Q = 9 \mu C$$

$$\text{others } Q = 4.5 \mu C$$

12. Two identical air-filled, parallel-plate capacitors each with capacitance $C = 0.01 \mu\text{F}$ are connected in parallel, charged to a potential difference of 10 V and then disconnected from any battery or external circuit (but they remain connected to each other).

A. If the separation of the plates is $d = 1 \mu\text{m}$, what is the area of a plate?

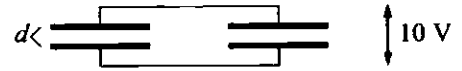

B. If we were to fill the entire air gap of the capacitor on the left with dielectric (dielectric constant $K = 4$), find the resulting potential difference between the plates?. Which plate (left or right) carries the larger charge?

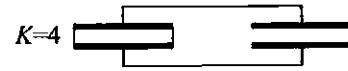

C. Again starting from the original situation, if we were to double the separation between the plates of the capacitor on the right, find the potential difference between the plates. Which plate (left or right) carries the larger charge?

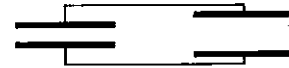

(A) $C = \frac{\epsilon_0 A}{d} \Rightarrow A = \frac{C d}{\epsilon_0} = \frac{10^{-8} \cdot 10^{-6}}{8.85 \times 10^{-12}} = \frac{10^{-14}}{8.85 \times 10^{-12}} = 1.13 \times 10^{-3} \text{ m}^2$

(B) $K=4 \Rightarrow C_L = .04 \mu\text{F} \Rightarrow C_{\text{eq}} = .05 \mu\text{F}$; same charge

$Q = C_i V_i = C_F V_F \Rightarrow V_F = \frac{C_i}{C_F} V_i = \frac{.02}{.05} 10 = 4 \text{ V}$

larger C , same $V \Rightarrow$ larger Q ... left has more Q

(C) $d \rightarrow d+2 \Rightarrow C_R = .005 \mu\text{F} \quad C_{\text{eq}} = .015 \mu\text{F}$

$V_F = \frac{C_i}{C_F} V_i = \frac{.02}{.015} \cdot 10 = 13.3 \text{ V}$

larger C , same $V \Rightarrow$ larger Q ... left again more Q

13. In the following circuit find the total current flowing through the battery and the current through the $3\text{ k}\Omega$ resistor. Hints: Direct application of Kirchhoff's Rules is not required: you can break this circuit into various fragments for which equivalences can be determined. Work systematically and show your work!

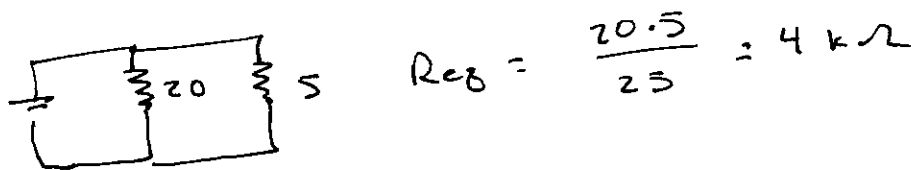
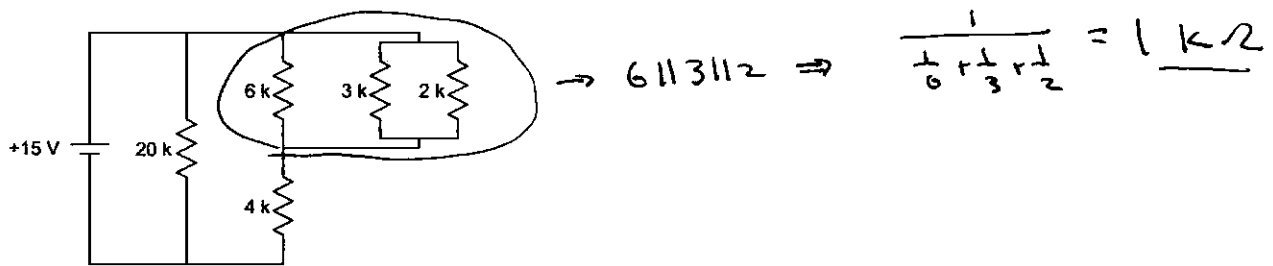

$$I = \frac{V}{R} = \frac{15}{4} = 3.75 \text{ mA} \quad (\text{thru battery})$$

$$\text{thru } 5\text{k}: \frac{15}{5} = 3 \text{ mA} \Rightarrow V = IR = (3 \text{ mA})(1 \text{ k}\Omega) = 3 \text{ V}$$

$$3 \text{ V across } 3 \text{ k}\Omega \Rightarrow I = \frac{V}{R} = \underline{1 \text{ mA}}$$

14. Using Kirchhoff's Rules find the current flowing in each wire of the given circuit. In solving this problem you will need to name and show current directions in each wire. Provide these names and directions by writing directly on the circuit diagram. You will also need to apply the loop rule to various loops around this circuit. For each such loop used, clearly show (by writing directly on the circuit diagram) the loop followed (including direction) and the resulting equation. Feel free to solve these equations using direct calculator methods, but record exactly what data (equations) you intended to type into your calculator. (Otherwise it is very difficult to give partial credit.)

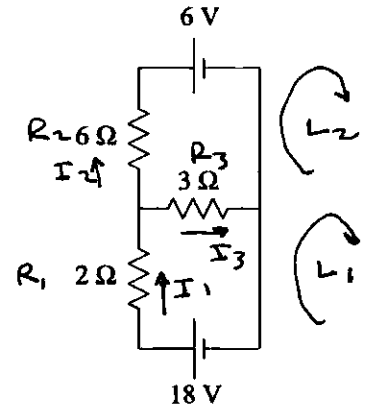

$$I_1 = I_2 + I_3$$

$$0 = -I_1 + I_2 + I_3$$

$$L_1: 18 - R_1 I_1 - R_3 I_3 = 0 \Rightarrow 18 = 2 I_1 + 3 I_3$$

$$L_2: -R_2 I_2 - 6 + R_3 I_3 = 0 \Rightarrow 6 = -6 I_2 + 3 I_3$$

$$\begin{bmatrix} -1 & 1 & 1 & 0 \\ 2 & 0 & 3 & 18 \\ 0 & -6 & 3 & 6 \end{bmatrix} \Rightarrow \text{calculator} \Rightarrow \begin{matrix} 4 = I_1 \\ .666 = I_2 \\ 3.33 = I_3 \end{matrix} \text{ Amp}$$

$$\begin{aligned} \text{alt: } 18 &= 2(I_2 + I_3) + 3I_3 = 2I_2 + 5I_3 \quad \times 3 \Rightarrow 54 = 6I_2 + 15I_3 \\ 6 &= -6I_2 + 3I_3 \end{aligned}$$

$$60 = 18I_3$$

$$6 = -6I_2 + 3\left(\frac{10}{3}\right) \Rightarrow \frac{10}{3} A = \frac{60}{18} = I_3$$

$$6I_2 = 4$$

$$I_2 = \frac{2}{3} A$$

$$I_1 = I_2 + I_3 = \frac{2}{3} + \frac{10}{3} = 4 A$$

15. In the circuit shown, $\mathcal{E} = 100 \text{ V}$, $R = 510 \text{ k}\Omega$, and $C = 3.3 \mu\text{F}$. The neon lamp L is generally a non-conductor, however, when the voltage across it exceeds 45 V it flashes for an instant (and during that instant it conducts like a wire). What is the time interval between flashes? If all the energy stored in the capacitor just before the flash is dissipated in the neon lamp, what is the average power dissipated in the neon lamp over the cycle?

$$\tau = RC = (510 \times 10^3) (3.3 \times 10^{-6}) = 1.683 \text{ s}$$

$$V_c = \mathcal{E} (1 - e^{-t/\tau})$$

\uparrow \uparrow
 45 100

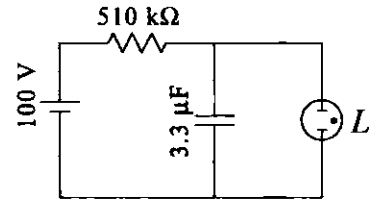

$$e^{-t/\tau} = 1 - \frac{V_c}{\mathcal{E}} \quad \Rightarrow \quad -\frac{t}{\tau} = \ln\left(1 - \frac{V_c}{\mathcal{E}}\right)$$

$$t = -\tau \ln\left(1 - \frac{V_c}{\mathcal{E}}\right)$$

$$= - (1.683) \ln\left(1 - \frac{45}{100}\right)$$

$$= \underline{1.01 \text{ sec}}$$

$$\text{Power} = \frac{\text{energy}}{\text{time}} = \frac{\frac{1}{2} C V^2}{t} = \frac{\frac{1}{2} (3.3 \times 10^{-6}) (45)^2}{1.01} = \underline{3.32 \text{ mW}}$$

When finished: insert your formula sheet inside this booklet, make sure your name is on the front cover, and place the resulting packet in the pile at the front of the classroom. Failure to include your formula sheet will result in lost points!